

# SAMPLE SOUND SETTINGS

The following examples below show a few of the many sonic possibilities of the EBS MultiComp.

## STANDARD COMPRESSION

The standard compression is achieved with the mode switch set to Normal position. Use moderate setting for compression and compensate for gain loss, or boost the signal with Gain.

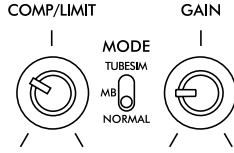

## MULTIBAND COMPRESSION

This is a very useful setting for tightening up your sound and obtaining maximum compression. Use a fairly high setting for compression and balance your sound the Gain control.

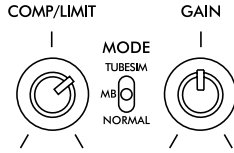

## TUBESIM MODE

Based on the normal on-band compressor, this setting adds tuba-alike harmonics to your sound. Useful when you wish to add extra warmth to your sound, and works very well with other instruments than bass or guitar.

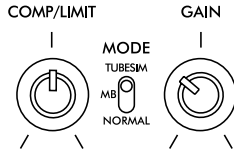

## MY PERSONAL SOUND

---



---



---



---

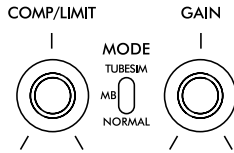

# USERS MANUAL

## BLACK LABEL SERIES

## EBS MULTICOMP



EBS PROFESSIONAL BASS EQUIPMENT

**INDICATOR LED** Indicates dynamically how the compressor works when active. This LED should glow when the pedal is switched on. When this LED stops lighting you should replace the battery as soon as possible.

**FOOT SWITCH** Switches the pedal on or off. This switch uses noiseless FT-switching for rapidly switching during play. Because of the active design, this switch performs better than what is normally called "true bypass".

**TUBESIM** - Activates the tube simulator, which adds extra harmonics and warmth to your sound, useful for spicing up your sound. Otherwise this mode operates as the normal position.

**MULTIBAND (MB)** - Selects the dual band compression. In this mode the bass and treble compressors work independently. Here you can achieve maximum compression effect without side-effects.

**NORMAL** - This position selects a normal one-band compressor action. Use moderate setting and compensate with the gain control for best result.



**COMP/LIMIT** - Controls the amount of compression, the compressor ratio. The range is from 1:1 (minimum position) up to 5:1 (maximum position).

**GAIN** - Controls the output gain of the compressor. Use this control to compensate the output level with reference to bypass. You can also use this control to boost your sound.



**ACTIVE/PASSIVE SWITCH** Set this switch to ACTIVE position if you are playing an active instrument or if you have the pedal connected to an effects loop. If you are playing a passive instrument, set this switch to PASSIVE. (next to input jack)

## THE CONTROLS

Thank you for purchasing the EBS Black Label MultiComp pedal!

EBS MultiComp is a high performance, analog compressor pedal with a choice between solid state, tube simulation and multi-band compression. With these impressive features the MultiComp makes a good sounding instrument sound even better.

We hope you'll enjoy using the EBS MultiComp pedal.



# HOW TO CHANGE BATTERY

- 1) Carefully remove the four screws holding the bottom plate.
- 2) Remove the bottom plate gently.
- 3) Replace the old battery with a new one of the same type, 9V alkaline type; 6LR61.
- 4) Gently place back the bottom plate, and make sure no cables are squeezed. Attach the four mounting screws using moderate tension.

# HOW TO USE THE EBS PHANTOM POWER™

The EBS Phantom Power System™ makes it possible to power the EBS MultiComp with 9V DC directly from the EBS Drome, Gorm, Fafner and 1V2/Classic amps. Here is a step-by-step instruction on how to do this.

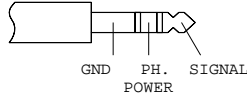

- 1) Connect a stereo 1/4" instrument cable (TRS, tip-ring-sleeve) between the EBS MultiComp pedal and the EBS amp.
- 2) Activate the phantom power on the amp. This is made with a flick of a switch on most EBS amps. Please consult the manual for the EBS amp you are using.
- 3) Connection done. You should now have power in the pedal, even if the input jack is left open.

## EBS PHANTOM POWER™ TROUBLE SHOOTING

Checkpoint	Action if answered NO
1) Is a 1/4" STEREO cable used between the pedal and the amp?	- Replace cable to a 1/4" STEREO cable. - Make sure the phantom power is activated on the amp.
2) Is there power available on the RING connection of the 1/4" plug?	- Check cable.

Note that only the pedal that is directly connected to the EBS amp can be powered with phantom power. This means that if you have more than one pedal, ONLY THE LAST one can use the EBS Phantom Power™.

# ADVANCED TECHNICAL OPTIONS (ONLY FOR AUTHORIZED PERSONNEL)

## ADJUSTING THRESHOLD LEVELS

The EBS MultiComp has the feature of fine-tuning the compressor thresholds for both the high and low band compressors independently. The ranges can be set from "off", which bypasses the desired band, up to a relative sensitivity of +6 dB from factory setting. These trimmers are set to 50% (12 o'clock) from factory.

**Make sure that the MultiComp operates in MULTIBAND mode when adjusting the threshold levels.**

The trimmers are located on the printed circuit board, and are easily accessible by removing the bottom plate. When doing any adjustments, please use a plastic screwdriver, and turn the trimmer gently.

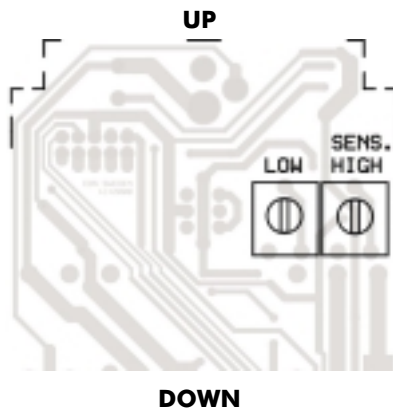

**! If you are not 100% sure on how to do this, please consult your nearest service center. Excessive force may result in damage to the unit, and the warranty in that case will be void.**

# TROUBLE SHOOTING GUIDE

Please consult the following checkpoints, before consulting one of the authorized EBS service centers.

Checkpoint	Action if answered NO
1) Does the cable(s) work properly?	- Replace cable(s).
2) Are the 1/4" plugs properly connected all the way in?	- Push the 1/4" plugs all the way in.
3) Are the Instrument cable attached to the Right (input) jack, and the Amp cable connected to the Left (output) jack?	- Reconnect input and output jacks.
4) Does the pedal have a battery, and is the battery OK?	- Put a new battery in the pedal.
5) Does the indicator LED light when pressing the foot switch alternatively?	- Replace battery.
6) Does the instrument work?	- Check the instrument at your nearest service center.
7) Does the amplifier work and is the volume turned up?	- Turn up volume or check the amp at your nearest service center.
8) If you are using a DC adapter, Are you using an EBS AD-9?	- Check the voltage and polarity of the adapter you are using.*

\*EBS Sweden AB guarantees no error free operation when using other DC adapter than the EBS AD-9. Warranty is void if higher voltage than 9.3 V has been used to feed the EBS MultiComp pedal.

# TECHNICAL SPECIFICATIONS EBS MULTICOMP

Nominal Input Level		-10 or -4 dB
Input Impedance		200 kohms
Bandwidth	+0/-3 dB	20 - 20k Hz
Gain Range		0 - 15 dB
Compressor Ratio	min/max	1:1 - 5:1
Threshold		-25 - +6 dB (adjustable inside)
Attack Time	(80%)	<10 ms
Release Time	(80%)	typ. 100 ms
Power Requirements		9 V DC Regulated, 15 mA max.
Dimensions	Width	2.8" (70 mm)
	Height	4.5" (115 mm)
	Depth	1.4" (35 mm)
Weight		450g (1 lb.)

Specifications are subject to change without notice.

\*EBS recommends the use of the EBS AD-9 DC adapter, which supplies a well stabilized power to the EBS MultiComp and all your other pedals that operate with a 9V battery. The high current capacity, 650mA, makes it possible to supply all pedals with only one adapter, EBS AD-9!



EBS Sweden AB · Framnäsbacken 12 · SE-171 66 Solna · Sweden  
 Phone: +46-8-7350010 · Fax: +46-8-7350015  
 Web: <http://www.ebs.bass.se>  
 E-mail: [ebs.sweden@bass.se](mailto:ebs.sweden@bass.se)